

Assembly Instructions

90° Fabric Clip SAU34

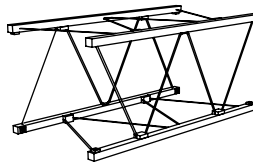

STOWaway®

PAT.US 6,715,255 B2

Folding Truss System

Step 1

Snap the **Fabric Clips** onto the **Truss** at the desired locations. Alternate orientation to insert fabric at a 90° angle.

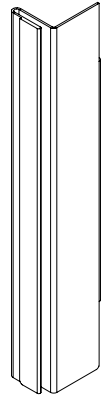
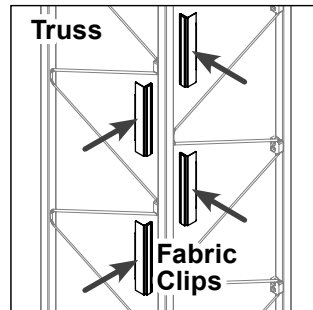

SAU34

Step 2

Slide the magnetic edge of the **Fabric** into the **Fabric Clip**. The **Magnet** will lock the fabric into position. Then pull the fabric moderately taut at a 90° angle to the magnet.

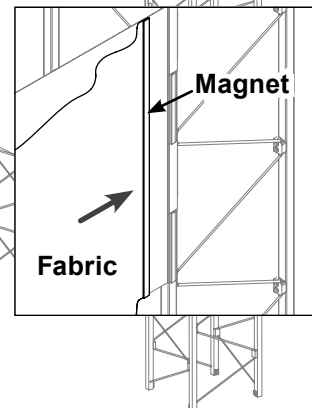
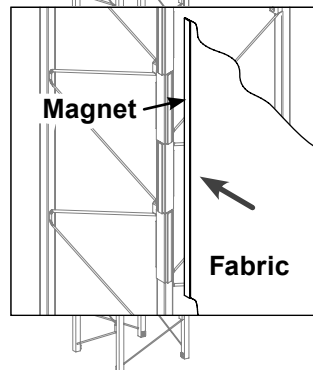

Step 3

Slide the magnetic edge of the **Fabric** into the **Fabric Clip**. The **Magnet** will lock the fabric into position. Then pull the fabric moderately taut at a 90° angle to the magnet.

Fabric Graphic Panel & Magnet Notes:

1. Fabric Panel should be 1" larger than outside dimensions of the truss (1/2" each side).
2. Critical! Artwork should be 2 1/2" away from the edge of the panel due to deformity from stretching.
3. Contact your fabric printing specialist for recommended types of fabric or ask Interlock for sources.
4. The magnet size should be 1/2" x 1/16".
5. Recommended attachment of the magnet is sewing it to the fabric.

IMPORTANT: ALL NOTES ARE RECOMMENDATIONS AND DO NOT ACCOUNT FOR VARIANCES IN THE FABRIC AND PRODUCTION OF THE GRAPHICS.

46037 - 08/02/06

INTERLOCK®

Interlock Structures International, Inc.



Member

7316 Aspen Lane North
suite 300
Minneapolis MN 55428-1109

e mail: info@interlockstructures.com
web: www.interlock.biz

voice: 763.425.1464
800.468.1497
fax: 763.425.8205