

Assembly Instructions

Connection Detail

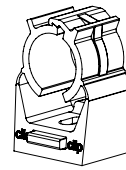

CLICclip

Step 1

Attach the **Clic Clip** to the **Tube** by pressing the Tube down or the Clic Clip up. Continue to press until the Clic Clic engages.

Step 2

Tighten the **Hardware** into the **Threaded Plate** in the Clic Clip.

Note: The Hardware will vary based on the connection method and what is being attached.

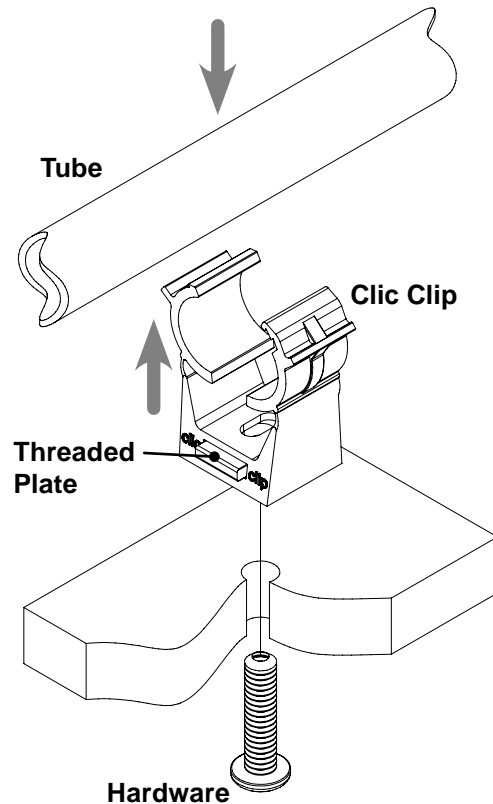

Step 3

To complete the connection tighten all hardware and check to see if the Clip Clip is engaged properly. The Clic Clip can be seated in either of the **grooves** in the mating half of the Clic Clip. As seen in the detail to the right.

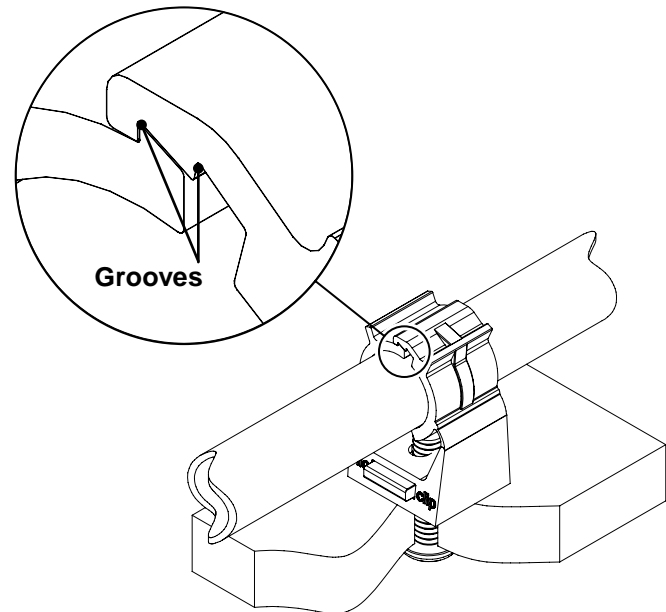

Important:

The Clic Clip is not meant for heavy loads. Incorrect use of the Clic Clip can result in failure. Please check with INTERLOCK to validate whether the Clic Clip is suited for your application.

42352 - 03/29/07

INTERLOCK
Interlock Structures International, Inc.



Member

7316 Aspen Lane North
suite 300
Minneapolis MN 55428-1109

e mail: info@interlockstructures.com
web: www.interlock.biz

voice: 763.425.1464
800.468.1497
fax: 763.425.8205