

Assembly Instructions

Connection Detail

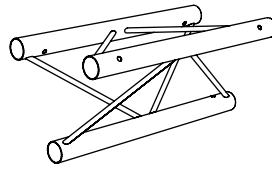

FORtruss™

Parts List: Quantities per Truss Tube

- (1) - Sleeve Connector
- (2) - 3/8-16 x 2 1/2" Hex Bolts
- (2) - 3/8-16 Self Locking Nuts

Step 1

Slide **Sleeve Connector** into **Truss Tube** and insert **3/8-16 Bolt** in the orientation shown. Fasten **3/8-16 Nut** tightly to 3/8-16 Bolts to assure maximum load capacity.

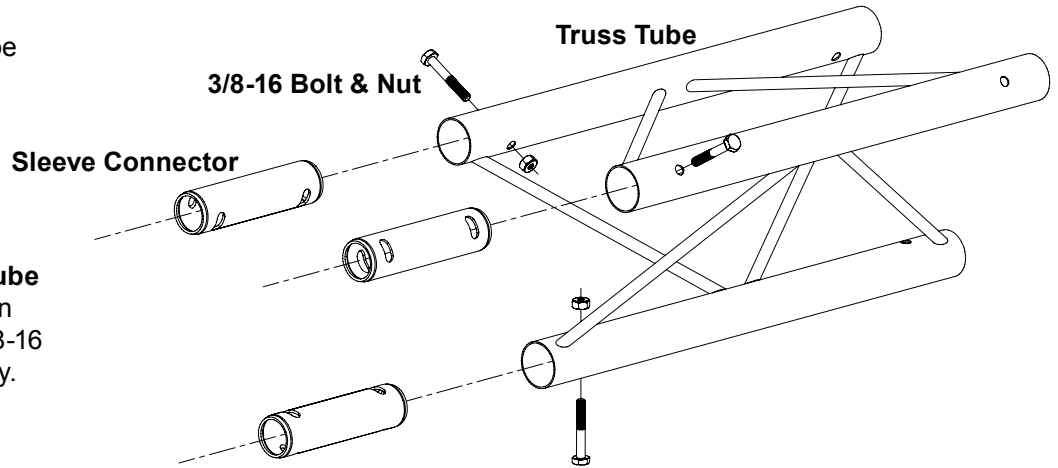

Step 2

Slide **Mating Truss** into position and insert 3/8-16 Bolt in the orientation shown. Fasten 3/8-16 Nut tightly to 3/8-16 Bolts to assure maximum load capacity.

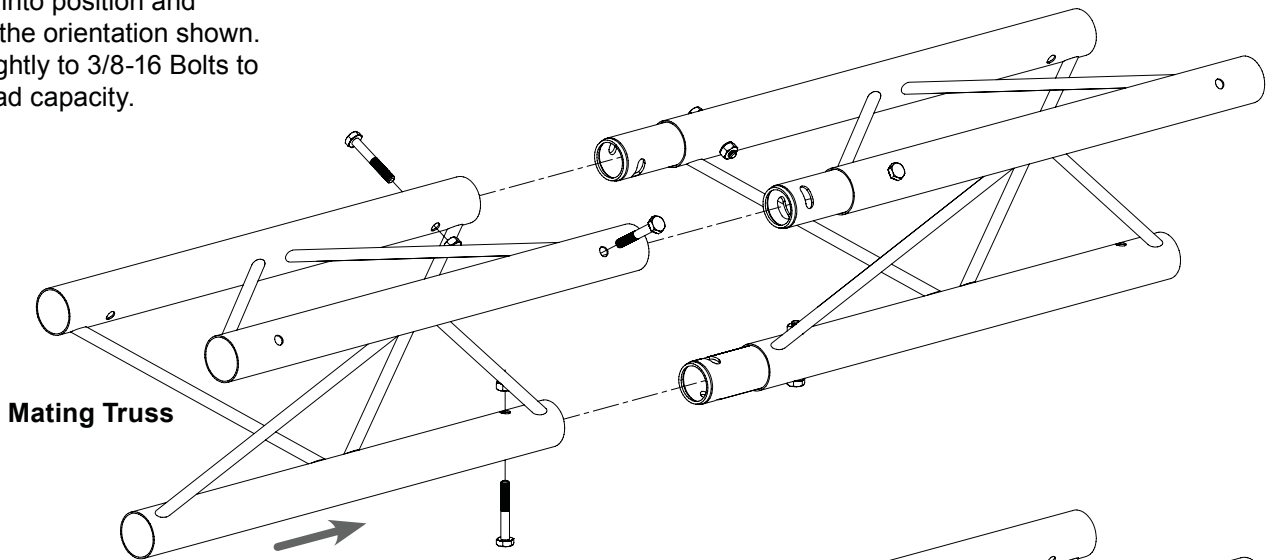

Step 3

Double check all bolts and nuts to ensure that they are securely tightened.

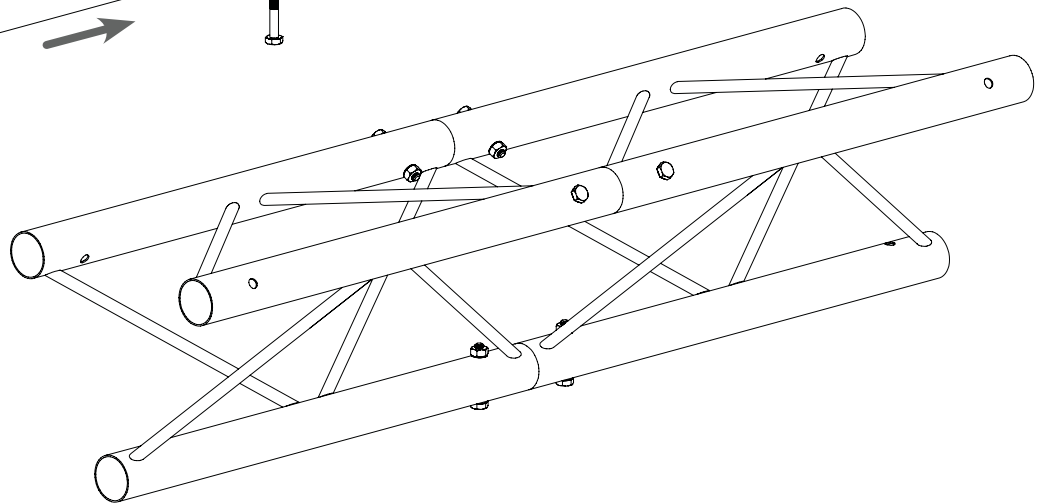

41803 07/31/07



Member

7316 Aspen Lane North
suite 300
Minneapolis MN 55428-1109

e mail: info@interlockstructures.com
web: www.interlock.biz

INTERLOCK[®]
Interlock Structures International, Inc.

voice: 763.425.1464
800.468.1497
fax: 763.425.8205